

ПИШЕМ ЦИФРЫ И ЧИСЛА

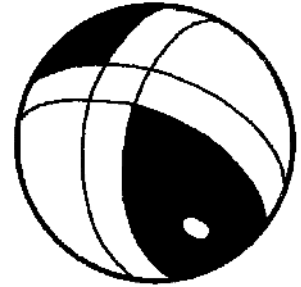

- Обведи по пунктиру цифру 1.

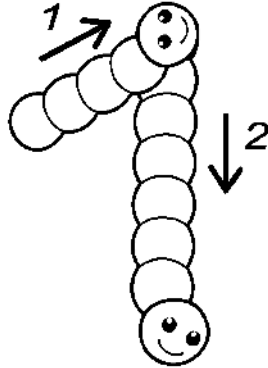

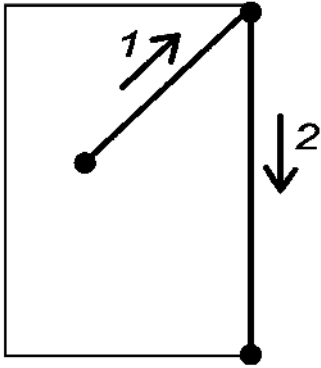
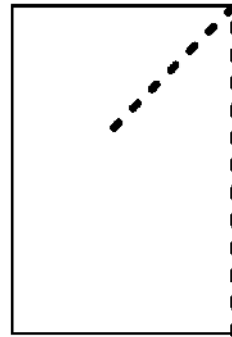
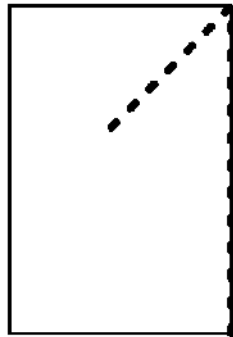
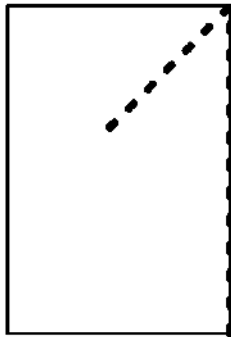
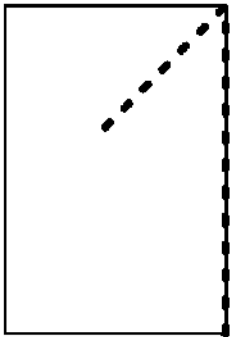

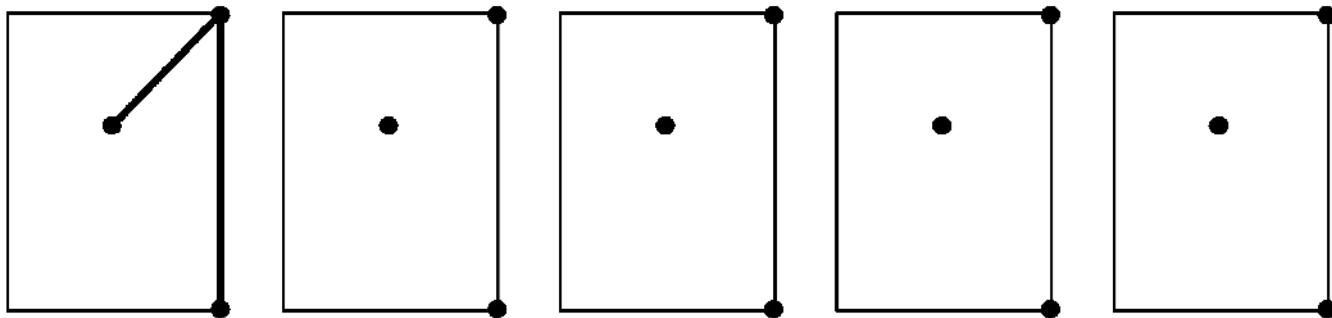
- Напиши по точкам цифру 1.

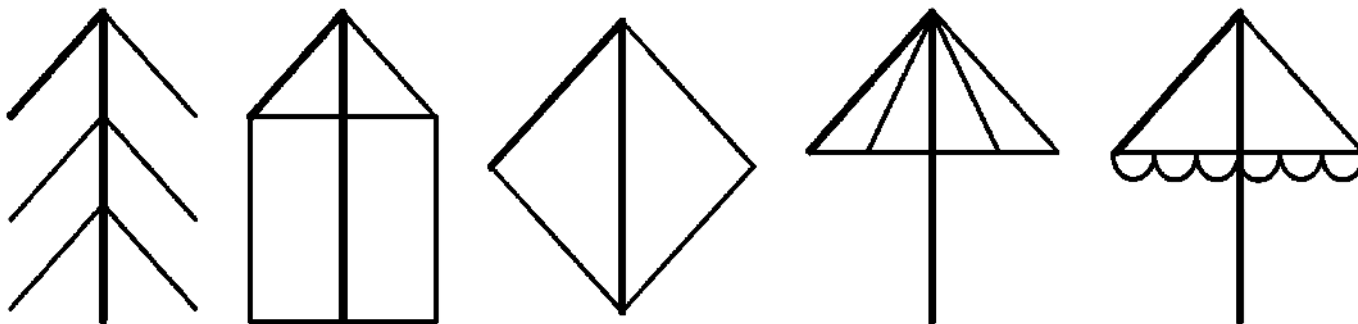

- Где на картинках спряталась цифра 1?

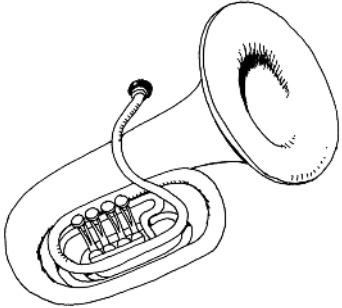
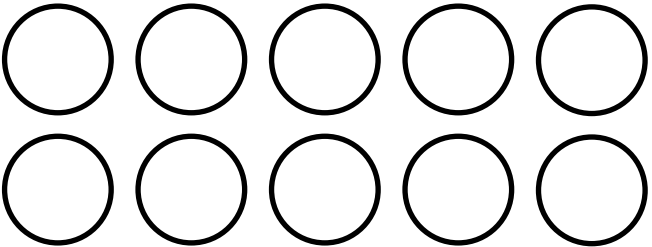

- Сосчитай, сколько предметов в каждой рамке. Раскрась столько же кружков справа.

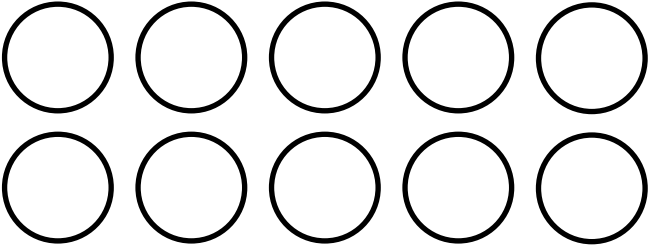
- Сосчитай, сколько предметов в каждой рамке.



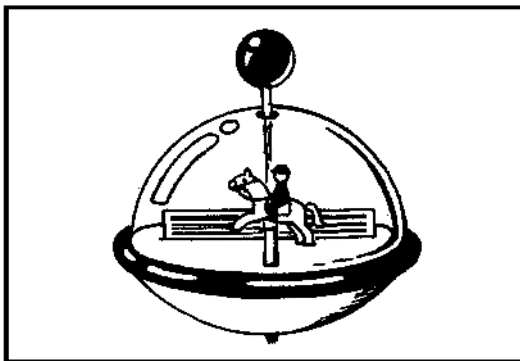
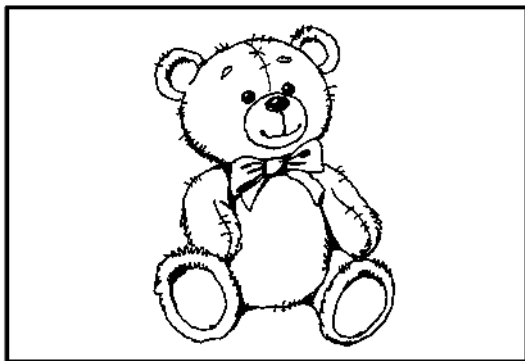

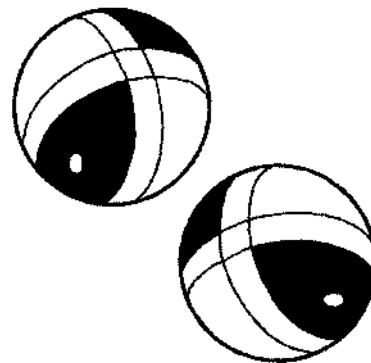
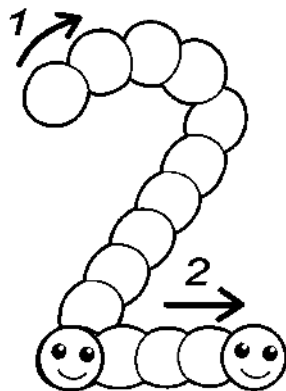
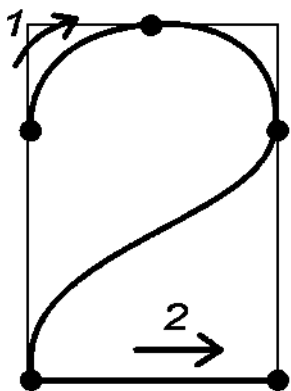
- Обведи по пунктиру цифру 2.

